



राजीव गांधी पेट्रोलियम प्रौद्योगिकी संस्थान

जायस, अमेठी-229304

उत्तर प्रदेश, भारत

**RAJIV GANDHI INSTITUTE OF PETROLEUM TECHNOLOGY
JAIS, AMETHI- 229304
UTTAR PRADESH, INDIA**

E-TENDER NOTICE

For

“Procurement of 01 No. Flow Loop Setup”

Rajiv Gandhi Institute of Petroleum Technology (RGIPT), Jais, Amethi, Uttar Pradesh has been established through an Act of the Parliament by the Ministry of Petroleum and Natural Gas (MoPNG), Government of India in 2008.

The Institute has been accorded the eminence of being an Institution of National Importance on the lines of the IITs. The Institute is associating with leading International Universities/ Institutions specializing in Petroleum Technology and Energy.

The Institute invites online bids from authorized Indian suppliers/OEM (Imported equipment/ Indigenous equipment) for the “**Procurement of 01 No. Flow Loop Setup**”.

CRITICAL DATE AND INFORMATION

Name of Work	Procurement of 01 No. Flow Loop Setup
Tender No.	RGIPT/JAIS/R&D/P-2109/SK/2022-23/01 Date: 24.02.2023
Date of Issue/publication of Tender Notice	27 Feb 2023, 4:00 P.M
Bid Document Download Date & Time	27 Feb 2023, 6:00 PM
Pre-Bid Meeting Date, Time & Venue (All queries shall be discussed in the Pre- Bid Meeting.)	6 th Mar 2023, 03:00 PM AB-1 5 th Floor Conference Room, RGIPT Campus Jais, Amethi U.P.
Bid Submission Start Date & Time	27.02.2023, 6:00 PM
Last Date and time of submission of Bids	20 th Mar 2023, 4:00 PM
Date and time of opening of Technical Bids	21 st Mar 2023 , 04:00 PM
Date and time of opening of Financial Bids	Shall be indicated separately after technical evaluation/ technical bid opening
Bid Address to the	The Director Rajiv Gandhi Institute of Petroleum Technology, Mubarakpur, Mukhtia, Bahadurpur Post: Harbanshganj, Jais, Amethi – 229304
Contact person & address for communication	Name: Dr. Shailesh Kumar Email: shaileshk@rgipt.ac.in Contact Nos. +91 8092722186

Notes:

1. Details regarding the tender are available on website of the Institute <https://www.rgipt.ac.in> and CPP Portal.
2. Tender document may be downloaded from above mentioned websites. Bidders are therefore, requested to visit the websites regularly to keep themselves updated. Any Addendum/Corrigendum will be displayed on the aforesaid websites only.
3. For submission of e-Bids, bidders are required to get themselves registered with CPP Portal.
4. **The HARD COPY of original Bid documents (Only Technical Bid documents) along with the payment proof pertaining to EMD and Tender processing fee to be sent to the Institute at the address indicated below on or before bid opening date/time as mentioned in critical date sheet.**

5. Tender documents received in incomplete shape or beyond the stipulated period shall not be entertained under any circumstances. The authority reserves the right to accept or reject any or all tenders without assigning any reason thereof.
6. Earnest Money Deposit (EMD) of Rs.50,000/- (Exempted in case of MSME registered, Udyam certificate to be enclosed) in the form of NEFT/Demand Draft, Fixed Deposit Receipt issued by any Nationalized Bank in favour of “**Rajiv Gandhi Institute of Petroleum Technology, payable at Jais**”.
7. **Tender Processing Fee (Non-Refundable Rs. 2000/- (Including GST)** Tender fee is exempted for MSME/UAM registered bidders as per Government of India norms

Bank Account Details of the Institute:

Name: Rajiv Gandhi Institute of Petroleum Technology

Bank: Bank of Baroda

Address: RGIPT Campus, Bahadurpur, Jais, Amethi.

Account No. 59480100000001

IFSC Code: BARB0JAICAM (5th Character is ZERO)

ADDRESS OF THE INSTITUTE:

RAJIV GANDHI INSTITUTE OF PETROLEUM TECHNOLOGY,
MUBARAKPUR, MUKHTIA MORE, BAHADURPUR,
POST: HARBANSHGANJ, JAIS, AMETHI, UTTAR PRADESH 229304,
WEBSITE: WWW.RGIPT.AC.IN

INTRODUCTION

Rajiv Gandhi Institute of Petroleum Technology (RGIPT), Jais, Amethi, Uttar Pradesh has been established through an Act of the Parliament by the Ministry of Petroleum and Natural Gas (MoPNG), Government of India in 2008.

The Institute has been accorded the eminence of being an Institution of National Importance on the lines of the IITs. The Institute is associating with leading International Universities/ Institutions specializing in Petroleum Technology and Energy.

The prime objective of the Institute is to provide education, training, and research to roll out efficient human resources, and to meet the growing requirements of the Petroleum and Energy sector.

The main campus of the Institute is located at Jais, Amethi, Uttar Pradesh and B. Tech., M. Tech., MBA and Ph.D. programmes from there. The Institute has set two centres, namely- Assam Energy Institute (AEI), Sivasagar and Energy Institute, Bengaluru (EIB) to offer Diploma and M. Tech. programmes respectively.

INSTRUCTIONS FOR ONLINE BID SUBMISSION (GUIDELINE FOR BIDDER):

The bidders are required to submit soft copies of their bids electronically on the CPP Portal, using valid Digital Signature Certificates. The instructions given below are meant to assist the bidders in registering on the CPP Portal, prepare their bids in accordance with the requirements and submitting their bids online on the CPP Portal.

More information useful for submitting online bids on the CPP Portal may be obtained at: <http://eprocure.gov.in/eprocure/app>.

1. Registration

(a) Bidders are required to enroll on the e-Procurement module of the Central Public Procurement Portal (URL: <http://eprocure.gov.in/eprocure/app>) by clicking on the link "Online bidder Enrollment" on the CPP Portal which is free of charge.

(b) As part of the enrolment process, the bidders will be required to choose a unique username and assign a password for their accounts.

(c) Bidders are advised to register their valid email address and mobile numbers as part of the registration process. These would be used for any communication from the CPP Portal.

(d) Upon enrolment, the bidders will be required to register their valid Digital Signature Certificate (Class II or Class III Certificates with signing key usage) issued by any Certifying Authority recognized by CCA India (e.g. Sift/ nCode / eMudhra etc.), with their profile.

(e) Only one valid DSC should be registered by a bidder. Please note that the bidders are responsible to ensure that they do not lend their DSC's to others which may lead to misuse.

(f) Bidder then logs in to the site through the secured log-in by entering their user ID/Password and the password of the DSC/ e-Token.

2. Searching for Tender Documents

(a) There is various search option built in the CPP Portal, to facilities bidders to search active tenders by several parameters. These parameters could include Tender ID, Organization Name, location, Date Value, etc. there is also an option of advanced search for tenders, wherein the bidders may combine a number of search parameters such as Organization Name, Form of Contract, Location, Date, Other keywords etc. to search for a tender published on the CPP Portal.

(b) Once the bidders have selected the tenders they are interested in, they may download the required documents/tender schedules. These tenders can be moved to the respective 'my Tenders' folder. This would enable the CPP Portal to intimate the bidders through SMS/e-mail in case there is any corrigendum issued to the tender document.

(c) The bidder should make a note of the unique Tender ID assigned to each tender, in case they want to obtain any clarification/help from the Helpdesk.

3. Preparation of Bids

(a) Bidder should consider any corrigendum published on the tender document before submitted their bids.

(b) Please go through the tender advertisement and the tender document carefully to understand the documents required to be submitted as part of the bid. Please note the number of covers in which the bid documents have to be submitted, the number of documents-including the names and content of each of the document that need to be submitted. Any deviations from these may lead to rejection of the bid.

(c) Bidder, in advance, should get ready the bid documents to be submitted as indicated in the tender document/schedule any generally, they can be in PDF/XLS/RAR/DWF/JPG formats. Bid document may be scanned with 100 dpi with black and white option which helps in reducing size of the scanned document.

(d) To avoid the time and effort required in uploading the same set of standard documents which are required to be submitted as a part of every bid, a provision of uploading such standard documents (e.g. PAN card copy, annual reports, auditor certificate etc.) has been provided to the bidders. Bidders can use “My space” or “Other Important Documents” area available to them to upload such documents. These documents may be directly submitted from the “My space” area while submitting a bid, and need not be upload again and again. This will lead to a reduction in the time required for bid submission process.

4. **Submission of Bids**

(a) Bidder should log into the site well in advance for bid submission so that they can upload the bid in time i.e. on or before the bid submission time. Bidder will be responsible for any delay due to other issues.

(b) The bidder has to digitally sign and upload the required bid documents one by one as indicated in the tender document.

(c) Bidders are required to note that they should necessarily submit their financial bids in the format provided and no other format is acceptable. If the price bid has been given as a standard BOQ format with the tender document, then the same is to be download and to be filled by all the bidders. Bidders are required to download the BoQ file, open it and complete the white colored (unprotected) cells with their respective financial quotes and other details (such as name of the bidder). No other cells should be changed. Once the details have been completed, the bidder should save it and submit it online, without changing the filename. If the BoQ file is found to be modified by the bidder, the bid will be rejected.

(d) The server time (which is displayed on the bidders’ dashboard) will be considered as the standard time for referencing the deadlines for submission of the bids by the bidders; opening of bids etc. the bidders should follow this time during bid submission.

(e) All the documents being submitted by the bidders would be encrypted using PKI encryption techniques to ensure the secrecy of the data. The data entered cannot be viewed by unauthorized persons until the time of bid opening. The confidentiality of the bids is maintained using the secured Socket Layer 128 bit encryption technology. Data storage encryption of sensitive fields is done. Any bid document that is uploaded to the server is subjected to symmetric encryption using a system generated symmetric key. Further this key is subjected to asymmetric encryption using buyers/bid opener’s public keys. Overall, the uploaded tender documents become readable only after the tender opening by the authorized bid openers.

(f) The uploaded tender documents become readable only after the tender opening by the authorized bid openers.

(g) Upon the successful and timely submission of bids (i.e. after Clicking “Freeze Bid Submission” in the portal), the portal will give a successful bid submission message & a bid summary will be displayed with the bid no. and the date & time of submission of the bid with all other relevant details.

(h) The bid summary has to be printed and kept as an acknowledgement of the submission of the bid, this acknowledgement may be used as an entry pass for any bid opening meetings.

5. **Assistance to Bidders**

(a) Any queries relating to the tender document and the terms and conditions contained therein should be addressed to the Tender Inviting Authority for a tender or the relevant contact person indicated in the tender.

(b) Any queries relating to the process of online bid submission or queries relating to CPP Portal in general may be directed to the 24*7 CPP Portal Helpdesk.

LIST OF DOCUMENTS TO BE UPLOADED

1. Bidder should take into account notifications, corrigendum published, if any on the tender document before submitting their bids.
2. Please go through the tender advertisement and the tender document carefully to understand the documents required to be submitted as part of the bid. Any deviations from these may lead to rejection of the bid.
3. The two-bid system will be followed for this tender. In this system, online offer should be submitted under **TWO-BID System** in two separate e-packets i.e. **“Technical eBid”** and **“Financial eBid”**.

Online Envelope No. 1: "Technical Bid" shall contain (Pdf format only)

Sl. No.	Details of Documents	Documents to be Uploaded	File Format
	<p>EMD (Earnest Money Deposit): a) The EMD of Rs. 50000/- (Rupees Fifty Thousand only) Exempted in case of MSME registered, certificate to be enclosed) in the form of NEFT/Demand Draft, Fixed Deposit Receipt, Bankers Cheque issued by any Nationalized Bank in favour of “Rajiv Gandhi Institute of Petroleum Technology, payable at Jais”. Bank Account Details of the Institute: Name: Rajiv Gandhi Institute of Petroleum Technology Bank: Bank of Baroda Address: RGIPT Campus, Bahadurpur Jais, Amethi. Account No. 5948010000001 IFSC Code: BARBOJAICAM (5th Character is ZERO)</p> <p>b) If any the firms registered with DGS&D, MSME & NSIC are exempted from payment of EMD provided such registration includes the item they are offering which are manufactured by them and not for selling products manufactured by other companies. (Latest Copy must be submitted online for claiming exemption)</p>	Payment Receipt	.pdf
1	Technical Specification Compliance Statement	Upload Technical Specification Compliance Statement on the letter head of the Company in prescribed format as given in Annexure - I	.pdf
2	Manufacturer’s Authorization Form	Upload Manufacturer’s Authorization Certificate in prescribed format as given in Annexure – 2 or Self Declaration of Manufacturing Unit	.pdf
3	Price Reasonability Certificate	Upload Price Reasonability Certificate on the letter head of the Company in prescribed format as given in Annexure - 3	.pdf

4	Declaration Certificate (Acceptance of terms & conditions of the tender) – In defined format (On the letter head of the Company) - Annexure –4 and Declaration Sheet as per Annexure - 4A .	Upload Declaration Certificate(Acceptance of terms & conditions of the tender) & Declaration Sheet on the letterhead of the Company in prescribed format as given in Annexure – 4 & 4A	.pdf
5	Non-Blacklisting Declaration - As on date of submission of the proposal, the Bidder is neither blacklisted by Central Government/State Government or Instrumentalities thereof nor is any criminal case against the Bidder/ its Partners/ Directors/ Agents pending before any court of law. Non-Blacklisting Certificate on Rs. 100.00 non-Judicial Stamp Paper –In defined format - Annexure - 5	Upload Non-Blacklisting Declaration on Rs. 100.00 non-Judicial Stamp Paper in prescribed format as given in Annexure – 5	.pdf
6	Copy of Firm Registration	Upload – Self Attested Copy of Firm Registration Certificate	.pdf
7	Copy of PAN Card & GST No.	Upload – Self Attested Copy of PAN Card & GST No.	.pdf
8	Experience: Bidder should have 3 years’ experience in the selling and providing “Flow Loop Setup” or similar upstream oil and gas equipment to reputed Central Government Institutes/Petroleum Engineering Colleges/ Universities/Oil Companies/ Research Institutes/ IITs/ NITs/ IISERs	Upload List of clients & Purchase Orders of Supply of “Flow Loop Setup” or similar upstream oil and gas equipment to the mentioned institutions.	.pdf
9	ISO Certificate: The Bidder or their OEM should possess any valid standard certification like ISO9001:2008 & 14001:2004.	Upload valid standard certification of the Companylike ISO	.pdf
10	Audited Annual Accounts: Bidder should enclose the copies of last 3 years Audited Annual Accounts(Balance Sheet) duly authenticated by Chartered Accountant	Upload the Self Attested Copies of last 3 years Audited Annual Accounts duly authenticated by Chartered Accountant (FY 2021-22, 2020-21, & FY 2019-20)	.pdf
11	Annual Turnover: Last three years CA certified turnover certificate (Average Turnover of last three years should be at least Rs. 12 lakhs (Rupees Twelve Lakhs only))	Upload the Self Attested Copy of CA certified Annual Turnover Certificate (FY 2021-22, 2020-21, & FY 2019-20)	.pdf
12	Last 3 year Income Tax Return (ITR)	Upload the Self Attested Copy of last 3-year Income Tax Return (ITR) – (FY 2021-22, 2020-21, & FY 2019-20)	.pdf
13	EMD Exemption -In case of exemption of EMD, the scanned copy of the document in support of exemption will have to be uploaded by the bidder during bid submission	Upload Self Attested Copy of MSME or any other valid certificate for EMD exemption	.pdf

14	MOST IMPORTANT: Document related to prior installation and service – At least 3 Academic and R&D National Organizations, Central and State Government Departments/ Institutions/PSU in the last 3 years.	Upload Self Attested Copies of 3 installations in Academic and R&D National Organizations, Central and State Government Departments/ Institutions/ PSU in the last 3 years. – Annexure - 6	.pdf
15	Any other relevant document (e.g., Item brochure, etc.)		.pdf

RGIPT, Jais, Amethi reserves the right to reject the bid if any of the above listed documents is not submitted.

Online Envelope 2: “Financial Bid” shall contain

1. The Financial Bid should be filled properly in the .xls/BoQ uploaded in the CPP portal.
2. Financial bids of the technically qualified bidders only will be opened, through CPP portal.
3. Financial bids must be offered in the format attached as per Specimen BoQ and tender document.
4. In case of any mistake or error in calculations or any discrepancy in the price quoted in word and figures, the LOWEST amount will be considered for comparison. If this lowest price is not acceptable to the bidder, their bid will be rejected. In this case, RGIPT, Jais, Amethi reserves the right to forfeit their EMD.

SECTION-II - INSTRUCTIONS TO THE BIDDERS (ITB)

Tenderers are advised to follow the instructions provided in the **Instructions to the Bidders** for the e-Submission of the bids online.

1. **Location of Supply & Installation of Equipment & Warranty Services:**
Rajiv Gandhi Institute of Petroleum Technology, Mubarakpur, Mukhetia More, Bahadurpur, Post: Harbanshganj, Jais, Amethi – 229304, Uttar Pradesh.
2. All the items covered in the Schedule of Requirements must be supplied within 12 weeks from the date of placement of purchase order. And after receipt of equipment, the same must be installed within a month's time.
3. **Amendment to Bidding Documents:**
 - a) At any time prior to the deadline for submission of bids, RGIPT, Jais, Amethi may, for any reason, whether on its own initiative or in response to the clarification request by a prospective bidder, modify the bid document.
 - b) The amendments to the tender documents, if any, will be notified by release of Corrigendum Notice on institute website against this tender. The amendments/modifications will be binding on the bidders.
 - c) RGIPT, Jais, Amethi at its discretion may extend the deadline for the submission of bids if it thinks necessary to do so or if the bid document undergoes changes during the bidding period, in order to give prospective bidders time to take into consideration the amendments while preparing their bids.
4. **Preparation of Bids**
Bidder should avoid, as far as possible, corrections, overwriting, erasures or postscripts in the bid documents. In case however, any corrections, overwriting, erasures or postscripts have to be made in the bids, they should be supported by dated signatures of the same authorized person signing the bid documents. However, bidder shall not be entitled to amend/ add/ delete/ correct the clauses mentioned in the entire tender document.
5. **Period of validity of bids:**
 - a) Bids shall be valid for a minimum of 180 days from the date of submission. A bid valid for a shorter period shall stand rejected.
 - b) RGIPT, Jais, Amethi may ask for the bidder's consent to extend the period of validity. Such request and the response shall be made in writing only. The bidder is free not to accept such request without forfeiting the EMD. A bidder agreeing to the request for extension will not be permitted to modify his bid.
6. **Deadline for Submission of Bids – online only:**
 - a) The Bid documents shall be neatly arranged. They should not contain any terms and conditions, printed or otherwise, which are not applicable to the Bid. ***The conditional bid will be summarily rejected.***
 - b) Bids must be received by RGIPT, Jais, Amethi before the due date and time at the address specified in the tender document.
 - c) RGIPT, Jais, Amethi may extend this deadline for submission of bids by amending the bid documents and the same shall be suitably notified on its website.
 - d) RGIPT, Jais, Amethi shall not be responsible and liable for **the delay in receiving the bid** for whatsoever reason.
7. **Institute's Right to amend/cancel:**
 - a) RGIPT, Jais, Amethi reserves the right to amend the eligibility criteria, commercial terms & conditions, Scope of Supply, technical specifications etc.
 - b) RGIPT, Jais, Amethi reserves the right to cancel the entire tender without assigning any reasons thereof.
8. **Corrupt or Fraudulent Practices:**
 - a) It is expected that the bidders who wish to bid for this tender have the highest standards of ethics.

- b) RGIPT, Jais, Amethi will reject bid if it determines that the bidder recommended for award has engaged in corrupt or fraudulent practices while competing for this contract.
- c) RGIPT, Jais, Amethi may declare a vendor ineligible, either indefinitely or for a stated duration, to be awarded a contract if it at any time determines that the vendor has engaged in corrupt and fraudulent practices during the award / execution of contract.

9. **Interpretation of the clauses in the Tender Document/ Contract Document**

- a) In case of any ambiguity/ dispute in the interpretation of any of the clauses in this Tender Document, the interpretation of the clauses by Director, RGIPT, Jais, Amethi shall be final and binding on all parties.

Chairman

SECTION III- ELIGIBILITY AND QUALIFICATION CRITERIA

The following documents should be submitted for eligibility and qualification in technical bid-

Sl. No.	Description
	<p>EMD (Earnest Money Deposit): a) The EMD of Rs. 50,000/- (Rupees Fifty Thousand only) Exempted in case of MSME registered, certificate to be enclosed) in the form of NEFT/Demand Draft, Fixed Deposit Receipt, Bankers Cheque issued by any Nationalized Bank in favour of “Rajiv Gandhi Institute of Petroleum Technology, payable at Jais”. Bank Account Details of the Institute: Name: Rajiv Gandhi Institute of Petroleum Technology Bank: Bank of Baroda Address: RGIPT Campus, Bahadurpur Jais, Amethi. Account No. 5948010000001 IFSC Code: BARBOJAICAM (5th Character is ZERO) b) If any the firms registered with DGS&D, MSME & NSIC are exempted from payment of EMD provided such registration includes the item they are offering which are manufactured by them and not for selling products manufactured by other companies. (Latest Copy must be submitted online for claiming exemption).</p>
1	Technical Specification Compliance Statement – (On the letter head of the Company) – Annexure - 1
2	Manufacturer’s Authorization Form – In defined format OR Self Declaration of Manufacturing Unit – Annexure – 2
3	Price Reasonability Certificate – In defined format (On the letter head of the Company) - Annexure – 3
4	Declaration Certificate (Acceptance of terms & conditions of the tender) – In Defined format (On the letter head of the Company) – Annexure – 4 and declaration Sheet as per Annexure – 4A .
5	As on date of submission of the proposal, the Bidder is neither blacklisted by Central Government/ State Government or Instrumentalities thereof nor is any criminal case against the Bidder/ its Partners/ Directors/ Agents pending before any court of law. Non-Blacklisting Certificate on Rs.100.00 non-Judicial Stamp Paper – In defined format – Annexure – 5
6	Copy of Firm Registration
7	Copy of PAN Card & GST No.
8	Bidder should have 3 years’ experience in the selling and providing “Flow Loop Setup” or similar oil and gas equipment to reputed Central Government Institutes/ / Universities/ Oil Companies/ Research Institutes/ IITs/ NITs/ IISERs (Self Declaration) – List of Clients & Purchase Orders of “Flow Loop Setup” or similar oil and gas equipment to be submitted.
9	The Bidder or their OEM should possess any valid standard certification like ISO9001:2008 & 14001:2004.
10	Bidder should enclose the copies of last 3 years Audited Annual Accounts (Balance Sheet and Profit & Loss A/c) duly authenticated by Chartered Accountant (FY 2021-22, 2020-21, & FY 2019-20)
11	Last three years CA certified turnover certificate (Average Turnover of last three years should be at least Rs. 12 lakhs (Rupees Twelve Lakhs only) (FY 2021-22, 2020-21, & FY 2019-20)
12	Last 3 year Income Tax Return (ITR) (FY 2021-22, 2020-21, & FY 2019-20)
13	In case of exemption of EMD, the scanned copy of the document in support of exemption will have to be uploaded by the bidder during bid submission. Relaxations/Preference to eligible bidders as per Public Procurement Policy for Micro and Small enterprises (MSEs) order, 2012 would be given.

14	MOST IMPORTANT: Document related to prior installation and service – Atleast 3 Academic and R&D National Organizations, Central and State Government Departments/Institutions/PSU in the last 3 years. Annexure – 6
----	---

MOST IMPORTANT: PLEASE DON'T ADD OR UPLOAD ANY ANNEXURE OF PRICE IN TECHNO-COMMERICAL BID DOCUMENTS, OTHERWISE YOUR BID WILL BE REJECTED.

SECTION IV: GENERAL CONDITIONS OF CONTRACT

1. **Tender filling up and submission**

- a. Tender offer must refer to the letter/Notice inviting the Tender.
- b. The bid should be uploaded online mentioning **“Procurement of 01 No. Flow Loop Setup” to Rajiv Gandhi Institute of Petroleum Technology, Jais, Amethi.**
- c. Bids must be submitted online against above-mentioned tender.
- d. The rates quoted should include all the components mentioned in the tender and should be valid for at- least 180 days from the date of opening of the bids. The rates must be quoted both in figures and words and overwriting should be avoided. However, all cuttings/corrections must be duly authenticated.
- e. The bid submitted must not contain any ambiguity. Any such ambiguity in the quote submitted shall make it liable for rejection.
- f. The tender document is not transferable.
- g. No amendment to the bid in any form by the bidder will be permitted after opening of the tender. No conditional offers shall be accepted.
- h. Submission of bid will bind the bidder to the acceptance of all conditions specified in the tender document.
- i. Canvassing in any form is forbidden and will be a criterion for disqualification.

2. **EMD (Earnest Money Deposit):**

- a) The EMD of Rs. 50,000/- (Rupees Fifty Thousand only) Exempted in case of MSME registered, certificate to be enclosed) in the form of NEFT/Demand Draft, Fixed Deposit Receipt, Bankers Cheque issued by any Nationalized Bank in favour of **“Rajiv Gandhi Institute of Petroleum Technology, payable at Jais”**. Bank Account Details of the Institute: Name: Rajiv Gandhi Institute of Petroleum Technology Bank: Bank of Baroda Address: RGIPT Campus, Bahadurpur Jais, Amethi. **Account No. 59480100000001, IFSC Code: BARBOJAICAM (5th Character is ZERO)**
- b) If any the firms registered with DGS&D, MSME & NSIC are exempted from payment of EMD provided such registration includes the item they are offering which are manufactured by them and not for selling products manufactured by other companies. (Latest Copy must be submitted online for claiming exemption).

3. **The earnest money deposit (EMD)** shall be submitted in Indian currency only. The bid security should remain valid for a period of 45 days beyond the final bid validity period.

- a) The EMD of the unsuccessful bidders will be returned after final award of the Job to a successful bidder/ acceptance of the tender and within reasonable time not exceeding six months from the date of opening of Tender. The EMD will carry no interest.
- b) The EMD will be forfeited if the bidder withdraws his offer before finalization of the tender.
- c) The EMD of successful bidder will be returned after the submission of Performance Security.
- d) The firms registered with DGS&D, MSME & NSIC, if any, are exempted from payment of EMD provided such registration includes the item they are offering which are manufactured by them and not for selling products manufactured by other companies. (Latest Copy must be submitted online for claiming exemption).
- e) Relaxations/Preference to eligible bidders as per Public Procurement Policy for Micro and Small enterprises (MSEs) order, 2012 would be given.

4. **Performance Security:** The successful bidder will provide “Performance Security” for an amount of **3% of the contract value** in the form of valid Account payee Demand Draft/ FDR from any of the scheduled bank favouring “Rajiv Gandhi Institute of Petroleum Technology” payable at RGIPT, Jais, Amethi Campus Branch. Performance security should remain valid at least for a period of 60 days beyond the date of completion of all contractual obligations of supplier (**Total Period of FDR/Demand Draft – Warranty Period plus 60 days**). Thereafter the security will be returned, provided there is no defect in the equipment supplied. (As per notification no. RGIPT/Jais/Admin/46/2021)

The performance security should remain valid at least for a period of 60 days of beyond the date of completion of all contractual obligations of supplier. (As per notification no. RGIPT/Jais/Admin/845/2020)

5. **Bid Validity:** The bid must be valid for 180 days from the date of submission.

6. **Technical Bid Evaluation Criteria:**

The Bid shall be evaluated as per rule-192 of GFR, 2017 by following the Quality and Cost Based Selection (QCBS) system.

Phase-I: Technical Evaluation

Technical evaluation (Marks based evaluation) will be done based on the information given by technical bid submitted by the bidders.

Bid containing partial, incomplete, un-cleared, and irrelevant information will be summarily rejected. Technical declaration must be supported with relevant documents. Discrepancy in relevant supporting documents and technical compliance sheet shall lead to rejection of the technical bids.

Phase-II: Financial Evaluation

- a) Financial bids of only technically qualified bidders shall be opened.
- b) Financial evaluation is purely done on the total financial implication.
- c) Any irrelevant, unreasonable assets rate quotes will be summarily rejected.

Evaluation of Technical and Financial Bids:

- a) Selection of the successful bidder shall be based on techno-commercial combined score. Weightage of 60% and 40% shall be given to technical criteria and financial bid respectively. Minimum technical score required is 70 marks out of 100 marks with qualification in each criteria. Any bidder scoring technical score of less than 70 marks will not be considered for financial evaluation.
- b) Technical Bids shall be opened first and evaluated for the bidder's eligibility criteria, bid completeness, bid conformity, bid responsiveness, before opening Financial Bid.
- c) Techno-Commercial Score: The final score shall be calculated for all technically qualified bidders using the formula: $[(\text{Technical score} / \text{Highest Technical Score}) \times 60\%] + [(\text{Minimum Financial quote} / \text{quoted price of the Bidder}) \times 40\%]$.
- d) The bidder with the highest Overall or Combined Score as computed above will be considered for engagement.
- e) The decision of RGIPT shall be final and binding on all the Bidders to this document. RGIPT reserves the right to accept or reject an offer without assigning any reason whatsoever.
- f) The financial bids shall be opened for the firms getting minimum 70 marks in technical evaluation.
- g) In case of a tie, preference will be given to the bidders who have secured higher technical score.

Note: Relaxations/Preference to eligible bidders as per Public Procurement Policy for Micro and Small enterprises (MSEs) order, 2012 would be given.

7. In order to understand profile of the firm and to have a clear understanding of the areas in which firm is having requisite expertise, RGIPT may at its absolute discretion invite one or more or all the bidders for further presentation.

8. **Special Instructions:**

- i) Non-receipt of quote in Indian currency may lead to the rejection of their bid without assigning any reason thereof.
- ii) RGIPT, Jais, Amethi avails GST concession under notification No. 47/2017 Integrated tax (rate) dated 14 November 2017, as amended time to time.

9. **Payment terms:**

In Indian Currency Payment Terms - 80% payment will be released against successful supply of equipment at site i.e Rajiv Gandhi Institute of Petroleum Technology, Jais, Amethi and balance 20% after installation & commissioning of the equipment and subject to submission of original Bill/ Invoice as certified by the Chairman, PEGE purchase committee.

10. **Clearance and delivery**: On arrival of shipment/consignment, the supplier is required to arrange custom clearance and transportation of the consignment up to RGIPT, Jais, Amethi premises. The Tenderer/ bidder will do all types of clearance work and formalities to deliver/provide the equipment at the site of installation. The expenses incurred will be reimbursed on actual basis not exceeding the quoted amount. Institute will provide all types of documentary support including Customs Duty exemption certificate. The custom duty, custom clearance charges, transportation charges etc. will be reimbursed in Indian Rupees on subject of submission of documentary proof. This may be included in your quotation as a separate item. Principals will themselves have to procure any requisite permission from the Govt. of country of origin of equipment.
11. **Part Shipment not allowed**: Part Shipment will NOT be allowed.
12. **Insurance**: For delivery of goods at the purchaser's premises, the insurance shall be obtained by the supplier in an amount equal to 110% of the value of the goods from "warehouse to warehouse" (final destinations) on "All Risks" basis including War Risks and Strikes. The insurance shall be valid for a period of not less than 3 months after installation and commissioning. If orders placed on CIF/CIP basis, the insurance should be up to RGIPT, Jais, Amethi.
13. **Bank Charges**: All the bank charges within India will be borne by the Institute and outside India will be borne by the Supplier.
14. **Site Preparation**: The supplier shall inform to the Institute about the site preparation, if any, needed for the installation of equipment, immediately after the receipt of the purchase order. The supplier must provide complete details regarding space and all the other infrastructural requirements needed for the equipment, which the Institute should arrange before the arrival of the equipment to ensure its timely installation and smooth operation thereafter. The supplier shall visit the Institute and see the site where the equipment is to be installed and may offer his advice and render assistance to the Institute in the preparation of the site and other pre-installation requirements.
15. **Resolution of Disputes**: The dispute resolution mechanism to be applied pursuant shall be as follows:
 - i. In case of Dispute or difference arising between the Purchaser and a domestic supplier relating to any matter arising out of or connected with this agreement, such disputes or difference shall be settled in accordance with the Indian Arbitration & Conciliation Act, 1996, the rules there under and any statutory modifications or re-enactments thereof shall apply to the arbitration proceedings. The dispute shall be referred to The Director, Rajiv Gandhi Institute of Petroleum Technology, Jais, Amethi and if he is unable or unwilling to act, to the sole arbitration of some other person appointed by him willing to act as such Arbitrator. The award of the arbitrator so appointed shall be final, conclusive and binding on all parties to this order.
 - ii. In the case of a dispute between the purchaser and a Foreign Supplier, the dispute shall be settled by arbitration in accordance with provision of sub-clause (a) above. But if this is not acceptable to the supplier then the dispute shall be settled in accordance with provisions of UNCITRAL (United Nations Commission on International Trade Law) Arbitration Rules.
The venue of the arbitration shall be the place from where the order is issued.
16. Live working product Demo of same or similar item is necessary (at the cost of bidder) for all the bidders, if asked for, within the ONE week of opening the technical bid.
17. **Printed Conditions of the Company – Not Acceptable to the Institute**: RGIPT does not accept the printed conditions of any Tenderer. It will be ignored without any reference; hence tenderers should withdraw such printed conditions if they have any. RGIPT shall accept only unconditional tender.

18. **Technical Deviations – Sole discretion of RGIPT for consideration:** If technical deviations furnished by the Tenderer are not agreeable to RGIPT, the offers may be ignored. However it will be solely at discretion of RGIPT to consider the technical deviations OR not for considering the Tenderer. No correspondences of the Tenderer will be entertained in this matter.
19. **Price Validity:** The price quoted by the bidder shall remain valid till the supply is completed. During the tenure of the supply period, no price increase will be considered, except for change in statutory levies imposed by Centre Govt. / state Govt. or Local authorities.
20. **Warranty:** As specified in the Technical Specification.
21. **Delivery:** The timely delivery of “**Flow Loop Setup**” is the essence of contract. The supply should be completed with the specified delivery. Delivery shall be completed must be supplied within 12 weeks from the date of placement of purchase order.
22. **Bid Acceptance and Rejection:**
 - a. RGIPT reserves the right to reject the bid without assigning any reason whatsoever.
 - b. RGIPT does not bind itself to accept the lowest or any quotation and reserves the right to reject any or all without assigning any reason.
23. **Late Receipt of Bids:** No bids will be accepted or considered after the due date and time.
24. **Liquidity Damage Clause:** RGIPT, Jais reserves the right to levy penalty @ of 0.5 % of order value per week of delay in supply and /or installation, beyond the schedule as mentioned in this tender document subject to maximum of 5% of the order value. RGIPT, Jais reserves the right to cancel the order in case the delay is more than 06 weeks. The delay in delivery and/or installation not attributed to supplier viz. delay in site preparation, delay in submission of required documents etc. and the conditions arising out of Force Majeure will not be considered for the purpose of calculating penalties.
25. **Ship to**

Dr. Shailesh Kumar
Chairman, Purchase Committee
Rajiv Gandhi Institute of Petroleum Technology
Ground Floor, Administrative Building, Mubarakpur, Mukhetia More, Bahdupur, POST:
Harbanshganj, Jais, Amethi – 229304 Uttar Pradesh
26. **Withdrawal of Tender:** The Institute reserves the right to withdraw the tender at any stage of tendering process with the approval of the Competent Authority.
27. **Replacements of Goods Broken, Damaged or Short:** If whole or part of the goods/ equipment supplied against the order is found defective/non-functional or without specification the supplier will have to replace the defective goods/equipment to make equipment operational within a reasonable time (not exceeding two months from the date of intimation to the supplier or the Indian Agent), failure to which the supplier will have to refund the full cost of the equipment including freight, Insurance etc.
28. **Force Majeure:** RGIPT, Jais may consider relaxing the penalty and delivery requirements, as specified in this document, if and to the extent that, the delay in performance or other failure to perform its obligations under the contract is the result of a Force Majeure. Force Majeure is defined as an event of effect that cannot reasonably be anticipated such as acts of God (like earthquakes, floods, storms etc.), acts of states / state agencies, the direct and indirect consequences of wars (declared or undeclared), hostilities, national emergencies, civil commotion and strikes at successful Bidder’s premises or any other act beyond control of the bidder.
29. **Arbitration:** All disputes/claims of any kind arising out of supply, commissioning, acceptance, warranty maintenance etc. under this Contract, shall be referred by either party (RGIPT, Jais or the bidder) after issuance of 30 days’ notice in writing to the other party clearly mentioning the nature of dispute to the Sole Arbitrator appointed by RGIPT, Jais. The arbitration proceedings shall be conducting in English and as per the provisions of Indian Arbitration and Conciliation Act, 1996. The decision of the Arbitrator shall be final and binding on both the parties.
30. **Jurisdiction:** The disputes, legal matters, court matters, if any shall be subject to Raebareli/ Amethi jurisdiction only.

31. A bid submitted with false information will not only be rejected but the vendor may also be debarred for participation in future tendering processes.
32. Authorized representative may choose to be present at the time of opening of quotation at their own cost.
33. **Only one PRICE BID should be submitted for the above equipment. A bidder who submits more than one PRICE BID, shall be disqualified and considered non- responsive.**

Chairman, Purchase Committee

“Procurement of 01 No. Flow Loop Setup”

Technical Specifications

Objectives of the Experimental Setup: The experimental Flow Loop Setup is to be used for the study of pressure drop and wax deposition during the flow of Heavy/Waxy crude oil (viscous crude oils)/oil-in-water emulsion samples through pipe flow test sections under varying flow rate and temperature conditions. The experiments will be performed on crude oils collected from different Indian oil fields, and the desired test sample will be stored in a sample container of setup during experiments. Crude oil shall be pre-heated and circulated through pipe flow test section, and differential pressure and temperature shall be monitored while gradually decreasing the temperature of the flow test section using a water bath. The setup will also be used for quantifying the efficiency of wax deposition inhibitors. The components used in the setup must be suitable for the flow of viscous crude oil samples.

The rough design of the experimental setup is given below:

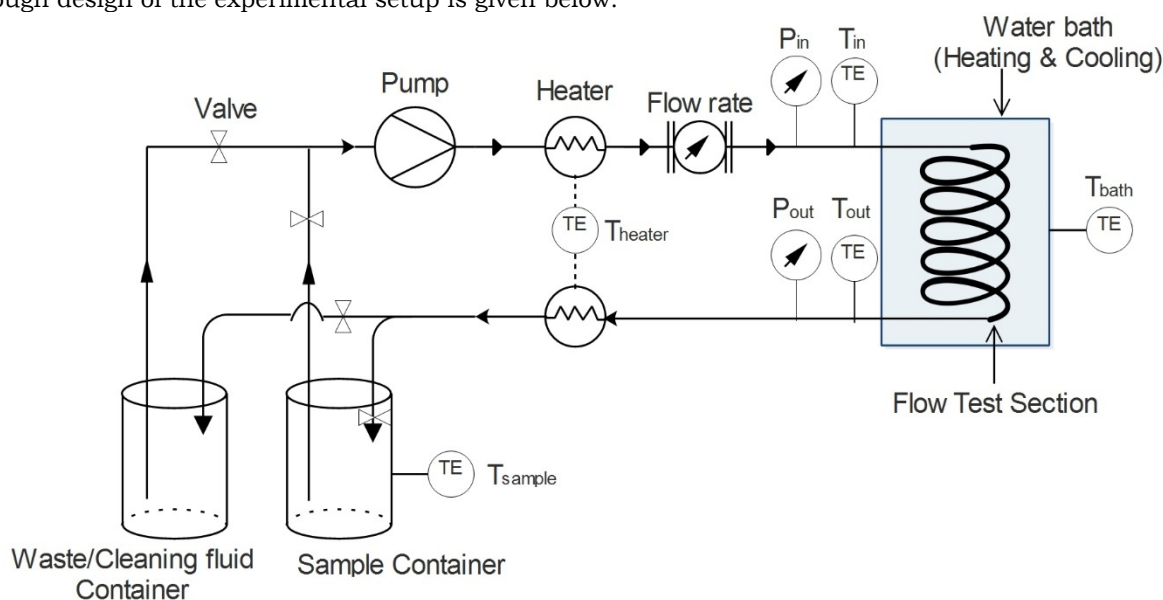

Technical Specifications	
Flow Test Section 1	<ul style="list-style-type: none"> - Length 10 met, diameter 1/8-inch - Helical coil shape - Submerged in temperature-controlled water bath
Flow Test Section 2	<ul style="list-style-type: none"> - Length 5 met, diameter ¼ inch - Helical coil shape - Submerged in temperature-controlled water bath
Flow Test Section 3	<ul style="list-style-type: none"> - Length 5 met, diameter 1/8 inch - Horizontally straight (2 met x 2 met) with single U-shape bend (1 met) - With 5 met jacketing of ¼ or 3/8-inch SS tubing for temperature control - With stand for keeping flow test section horizontal
Circulating Water Bath (PID controlled)	<ul style="list-style-type: none"> - To control and achieve the desired temperature of flow test sections - Provision for both heating and cooling (with in the entire temperature range) - Temperature: 1 to 90 °C, or better (Accuracy ±1 °C) - Digital display
Pump	<ul style="list-style-type: none"> - Suitable Gear pump for continuous recirculation of viscous heavy/waxy crude oils (having viscosity up to 200 cp or more at 65 °C) <i>(other pump, e.g., dual syringe pump, may also be quoted based on suitability supported with proper documents)</i> - Digital display - Flow rate: 15 to 40 ml/min, or better - Max. delivery pressure: atm to 250 psi, or better - Max. operating temperature: 80 °C, or better
Flow meter	<ul style="list-style-type: none"> - Suitable to measure continuous flow discharge of pump
Line heaters	<ul style="list-style-type: none"> - To control and indicate the temperature of flow line - Max. temperature rating: 100 °C, or better
Digital Pressure Sensors	<ul style="list-style-type: none"> - Installed at inlet (P_{in}) and outlet (P_{out}) of flow test section - P_{in}: 0-1000 psi, ±0.1% Accuracy, or better - P_{out}: 0-100 psi, ±0.25% Accuracy, or better
Digital Temperature sensors	<ul style="list-style-type: none"> - Installed at inlet-outlet of flow test section, at heaters, and at sample container - 0-100 °C

Sample container	- 1000 ml capacity - With heating (up to 100 °C, or better) and stirring capacity - With thermal insulation or thermal jacket
Waste/cleaning fluid container	- 1000 ml capacity
Valves	To control flow of sample and cleaning fluid
Connectors	To easily interchange flow test sections
Material of wetted part	All wetted parts material must be able to handle crude oil
Electronic control, real time data acquisition and local display	Complete setup must be electronically controlled with power supply and should have the provision of local display (HMI screen) of all associated data (temperature, pressure, and flow data). (valves can be manually/electronically controlled)
Data acquisition software	To store, display and export associated data in real time in external PC
Mounting Panel	Complete setup (including all components) must be mounted on a common platform in a space-efficient manner
Wetted Part Material	Must be able to handle viscous crude oil (e.g., SS316 grade or better)
Warranty	Minimum One-year comprehensive on-site warranty after successful installation of the setup

General requirements

1. The supplier shall be responsible for the installation, commissioning and test run of the equipment to the satisfaction of the user, within 30 days of delivery. The firm shall provide atleast one day training on proper operation of setup to the user.
2. All the manuals necessary for operating and servicing will have to be provided along with supply of the setup.
3. Since setup is design based and to be fabricated, its performance must meet the desired objectives. The firms must assure to fulfil indented need with their offered setup, otherwise the offer will be rejected.
4. The user inputs during fabrication of the setup and the software, after final acceptance, must be considered.
5. Bidder should give each detail of fabrication so that the suitability of offered setup with user's need could be compared. This should essentially cover these points:
 - a) Actual Drawing of offered setup with dimensions.
 - b) List of Main Units/Parts/Components to be used with Make/Model and their technical detail.
 - c) Detail of auxiliary parts.
 - d) Detail of piping with material, thickness, and size.
 - e) Outer dimension of the whole assembly to know the total space it will occupy.
6. Qualified Service Engineer and customer support staff should be available with the firm to attend to the fault within 15 days.
7. Firm must provide extra sets of spare/consumable parts for the smooth operation of setup for at least two years.
8. The firm must provide a 'Technical Compliance Report' against each specification and additional requirements.

Optional:

AMC: AMC for 3 years after the warranty period may be separately quoted and AMC must include Spares, Consumables and Service Engineer charges.

Place:

Date:

Signature and seal of the Manufacturer/ Bidder

Technical Specifications Compliance Statement of “Procurement of 01 No. Flow Loop Setup” should be submitted as per format given in Annexure – I (On the Company’s Letter Head)

Annexure-1

TECHNICAL SPECIFICATIONS COMPLIANCE STATEMENT

Online Tenders from authorized Indian suppliers/OEM (Imported equipment/ Indigenous equipment) for procurement of **1 No. of Flow Loop Setup** are invited by the Rajiv Gandhi Institute of Petroleum Technology, Amethi- 229304 in **Two-Part Bid System** as per specifications mentioned below:

Please mention the brand and model no. & name of the equipment:

Technical Specifications	Bidder’s Specification	Compliance/ Deviation
Flow Test Section 1	<ul style="list-style-type: none"> - Length 10 met, diameter 1/8-inch - Helical coil shape - Submerged in temperature-controlled water bath 	
Flow Test Section 2	<ul style="list-style-type: none"> - Length 5 met, diameter ¼ inch - Helical coil shape - Submerged in temperature-controlled water bath 	
Flow Test Section 3	<ul style="list-style-type: none"> - Length 5 met, diameter 1/8 inch - Horizontally straight (2 met x 2 met) with single U-shape bend (1 met) - With 5 met jacketing of ¼ or 3/8-inch SS tubing for temperature control - With stand for keeping flow test section horizontal 	
Circulating Water Bath (PID controlled)	<ul style="list-style-type: none"> - To control and achieve the desired temperature of flow test sections - Provision for both heating and cooling (with in the entire temperature range) - Temperature: 1 to 90 °C, or better (Accuracy ±1 °C) - Digital display 	
Pump	<ul style="list-style-type: none"> - Suitable Gear pump for continuous recirculation of viscous heavy/waxy crude oils (having viscosity up to 200 cp or more at 65 °C) <i>(other pump, e.g., dual syringe pump, may also be quoted based on suitability supported with proper documents)</i> - Digital display - Flow rate: 15 to 40 ml/min, or better - Max. delivery pressure: atm to 250 psi, or better - Max. operating temperature: 80 °C, or better 	
Flow meter	<ul style="list-style-type: none"> - Suitable to measure continuous flow discharge of pump 	
Line heaters	<ul style="list-style-type: none"> - To control and indicate the temperature of flow line - Max. temperature rating: 100 °C, or better 	
Digital Pressure Sensors	<ul style="list-style-type: none"> - Installed at inlet (P_{in}) and outlet (P_{out}) of flow test section - P_{in}: 0-1000 psi, ±0.1% Accuracy, or better - P_{out}: 0-100 psi, ±0.25% Accuracy, or better 	

Digital Temperature sensors	- Installed at inlet-outlet of flow test section, at heaters, and at sample container - 0-100 °C		
Sample container	- 1000 ml capacity - With heating (up to 100 °C, or better) and stirring capacity - With thermal insulation or thermal jacket		
Waste/cleaning fluid container	- 1000 ml capacity		
Valves	To control flow of sample and cleaning fluid		
Connectors	To easily interchange flow test sections		
Material of wetted part	All wetted parts material must be able to handle crude oil		
Electronic control, real time data acquisition and local display	Complete setup must be electronically controlled with power supply and should have the provision of local display (HMI screen) of all associated data (temperature, pressure, and flow data). (valves can be manually/electronically controlled)		
Data acquisition software	To store, display and export associated data in real time in external PC		
Mounting Panel	Complete setup (including all components) must be mounted on a common platform in a space-efficient manner		
Wetted Part Material	Must be able to handle viscous crude oil (e.g., SS316 grade or better)		
Warranty	Minimum One-year comprehensive on-site warranty after successful installation of the setup		

General Requirement	Bidder's Compliance/Deviation
The supplier shall be responsible for the installation, commissioning and test run of the equipment to the satisfaction of the user, within 30 days of delivery. The firm shall provide atleast one day training on proper operation of setup to the user.	
All the manuals necessary for operating and servicing will have to be provided along with supply of the setup.	
Since setup is design based and to be fabricated, its performance must meet the desired objectives. The firms must assure to fulfil indented need with their offered setup, otherwise the offer will be rejected.	
The user inputs during fabrication of the setup and the software, after final acceptance, must be considered.	
Bidder should give each detail of fabrication so that the suitability of offered setup with user's need could be compared. This should essentially cover these points: <ul style="list-style-type: none"> • Actual Drawing of offered setup with dimensions. • List of Main Units/Parts/Components to be used with Make/Model and their 	

technical detail. <ul style="list-style-type: none"> • Detail of auxiliary parts. • Detail of piping with material, thickness, and size. • Outer dimension of the whole assembly to know the total space it will occupy. 	
Qualified Service Engineer and customer support staff should be available with the firm to attend to the fault within 15 days.	
Firm must provide extra sets of spare/consumable parts for the smooth operation of setup for at least two years.	
The firm must provide a 'Technical Compliance Report' against each specification and additional requirements.	

Technical Specifications Compliance Statement of "Flow Loop Setup" should be submitted as per format given in Annexure - I (On the Company's Letter Head)

MANUFACTURERS' AUTHORIZATION FORM (MAF) (ON THE LETTER HEAD OF THE COMPANY)

[NOTE: The Bidder shall require the Manufacturer to fill in this Form in accordance with the instructions indicated. This letter of authorization should be **on the letterhead of the Manufacturer** and should be signed by a person with the proper authority to sign documents that are binding on the Manufacturer. It should be included by the Bidder in its bid]

No. Dated

Date: [insert date (as day, month and year) of Bid Submission] Tender No.: [insert number from Invitation for Bids]

To,
The Director
Rajiv Gandhi Institute of Petroleum Technology Mubarakpur, Mukhtia, Bahadurpur
POST: Harbanshganj, Jais, Amethi - 229304

WHEREAS

We [insert complete name of Manufacturer], who are official manufacturers of [insert type of goods manufactured], having factories at [insert full address of Manufacturers factories], do hereby authorize [insert complete name of Bidder] to submit a bid the purpose of which is to provide the following Goods, manufactured by us [insert name and or brief description of the Goods], and to subsequently negotiate and sign the Contract.

We hereby extend our full guarantee and warranty in accordance with the General Conditions of Contract, with respect to the Goods offered by the above firm.

Signed: [insert signature(s) of authorized representative(s) of the Manufacturer] **Name:** [insert complete name(s) of authorized representative(s) of the Manufacturer] **Title/Designation:** [insert title]

Duly authorized to sign this Authorization on behalf of: [insert complete name of Bidder]

Dated on _____ day of _____, _____ [insert date of signing] Yours faithfully,
(Name of manufacturers)

OR

SELF DECLARATION OF MANUFACTURING UNIT

PRICE REASONABILITY CERTIFICATE
(ON THE LETTER HEAD OF THE COMPANY)

It is certified that the rates quoted against Tender No. Datedfor the items vide our bid No. datedare exclusively for supply to ACADEMIC and RESEARCH Institutions and are not more than as charged to other Govt./PSU's for similar supplies made in recent past. If they have been approved by the Director, RGIPT and if at any stage it has been found that the quoted rates are higher than the rates applicable to supply to Government then in such condition RGIPT, Amethi, will have the right to cancel the approved rates and to take legal action against the tenderer.

Yours faithfully,

(Name of manufacturers)(Signature with date) (Name and designation)

Duly authorized to sign tender for and on behalf of

DECLARATION (ACCEPTANCE OF TERMS & CONDITIONS)
(ON THE LETTER HEAD OF THE COMPANY)

1. I,Son/Daughter of ShriProprietor/
Partner/CEO/MD/Director/Authorized Signatory of M/s..... am
competent to sign this tender document.

- A. I have carefully read and understood all the terms and conditions of the tender and hereby convey my acceptance of the same.
- B. The information/ documents furnished along with the above application are true and authentic to the best of my knowledge and belief.
- C. I/ we/ am are well aware of the fact that furnishing of any false information/ fabricated document would lead to rejection of my tender at any stage besides liabilities towards prosecution under appropriate law.
- D. Each page of the tender document and papers submitted by my Company is authenticated, sealed and signed, and I take full responsibility for the entire documents submitted.

Date: -----

Place: -----

Signature of the Authorized Person

Full Name: -----

Company Seal: -----

DECLARATION SHEET

We, _____ hereby certify that all the information and data furnished by our organization with regard to this tender specification are true and complete to the best of our knowledge. I have gone through the specification, conditions and stipulations in details and agree to comply with the requirements and intent of specification.

This is certified that our organization has been authorized (Copy attached) by the OEM to participate in Tender. We further certified that our organization meets all the conditions of eligibility criteria laid down in this tender document. Moreover, OEM has agreed to support on regular basis with technology / product updates and extend support for the warranty.

The prices quoted in the financial bids are subsidized due to academic discount given to RGIPT, Jais, Amethi.

We, further specifically certify that our organization has not been Black- Listed/ De Listed or put to any Holiday by any Institutional Agency/ Govt. Department/Public Sector Undertaking in the last three years.	
1. Phone	
2. Fax	
3. E-mail	
4. Contact Person Name	
5. Mobile Number	
6. TIN Number	
7. PAN Number	
8. (In case of on-line payment of TenderFees) UTR No. (For Tender Fee)	
9. (In case of on-line payment of EMD)UTR No. (For EMD)	
10. Kindly provide bank details of thebidder in the following format: a) Name of the Bank	
b) Account Number	
c) Kindly attach scanned copy of one Cheque book page to enable us to return the EMD to unsuccessful bidder	

(Signature of the Tenderer)Name:

Seal of the Company

NON-BLACKLISTING DECLARATION

It has been certified that all information provided in tender form is true and correct to the best of my knowledge and belief. No forged / tampered document(s) are produced with tender form for gaining unlawful advantage. We understand that RGIPT, Amethi is authorized to make enquiry to establish the facts claimed and obtain confidential reports from clients.

In case it is established that any information provided by us is false / misleading or in the circumstances where it is found that we have made any wrong claims, we are liable for forfeiture of EMD and or any penal action and other damages including withdrawal of all work/purchase orders being executed by us. **Further RGIPT, Amethi is also authorized to blacklist our firm/company/agency and debar us in participating in any tender/bid in future.**

I / We assure the Institute that neither I / We nor any of my / our workers will do any act/s which is improper / illegal during the execution in case the tender is awarded to us.

Neither I/We nor anybody on my/our behalf will indulge in any corrupt activities/practices in my/our dealing with the Institute.

Our Firm/Company/Agency is not been blacklisted or banned by any Central Government Department/ State Government Department, PSU, University, Autonomous Institute or Any other Govt. Organization.

Date

Signature of the Tenderer

Place Stamp

Note: This certificate should be executed on duly notarized ` 100/- Non Judicial Stamp Paper.

List of Govt. Organization/Department/Institutes

List of Government Organization/Department/Institutes for whom the Bidder has undertaken such work during last three years (must be supported with work orders)		
Name of the Organization	Name of Contact Person	Contact No.

(Signature of the Tenderer)

Name:

Seal of the Company

FINANCIAL BID – Procurement of 01 No. Flow Loop Setup

(To be filled in BoQ Format on CPP Portal)

Financial Bid in Indian Currency:

- I. Name of the Bidder/Tenderer:
Name & Model No of offered goods:
Tender No.:**

Sl. No.	Details	Total Amount (In INR)
1	Basic Cost of “01 No. Flow Loop Setup” defined in Technical Specifications Statement of the Tender	
2	Comprehensive Cost of Warranty	
3	Add: Packing & Forwarding Charges, If any	
4	Add: Installation & Commissioning Charges, if any	
5	Add: Transportation Charges up to RGIPT, Jais, Amethi, if any	
6	Add: GST (Taxes)	
Total Price (Sum of Sl. No 1 to 6) F.O.R RGIPT, Jais, Amethi Price		

II. For Local Supplies -

Sl. No.	Details	Total Amount (In INR)
1	Cost of Local Supplies defined in Technical Specifications Statement of the Tender Document (Please mention the items)	
2	Add: Packing & Forwarding Charges, If any	
3	Add: Installation & Commissioning Charges, if any	
4	Add: Transportation Charges up to RGIPT, Jais, Amethi, if any	
5	Add: Cost of Warranty	
6	Add: GST (Taxes)	
Total Price (Sum of Sl. No 1 to 6) F.O.R RGIPT, Jais, Amethi Price		

- I. Total Bid price in Indian Currency (Equipment Cost with accessories):
.....In words.....
- II. Total Bid price in Indian currency (Local Supplies):
In words:.....

Grand Total (I + II) =
In words:

- a) Indian Agents Name & Address
b) The cost of optional items shall be indicated separately

Date
Place

Signature of the Tenderer
Stamp